



**VISTA
PROFESSIONAL
OUTDOOR
LIGHTING**

INSTALLATION INSTRUCTIONS

4250

12V SERIES

Step and Brick Lights

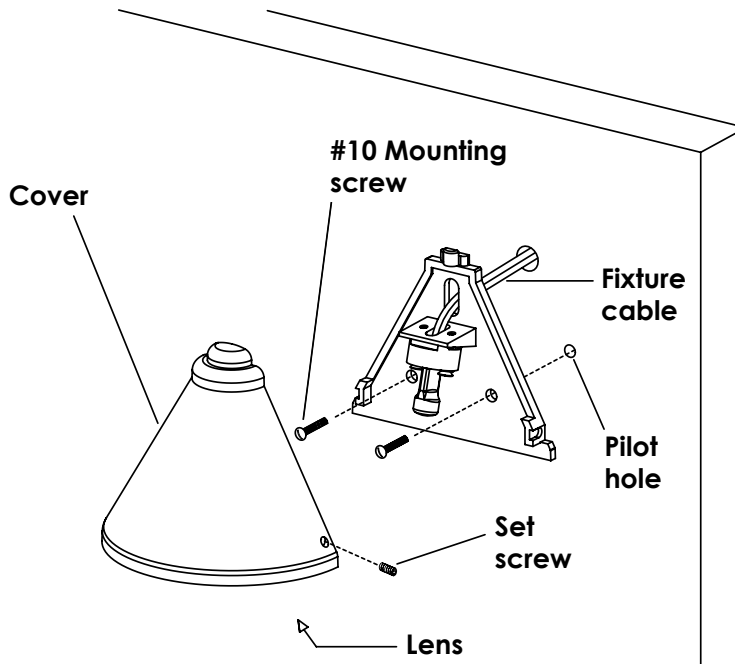

TOOLS REQUIRED FOR INSTALLATION:

- Wire strippers
- Blade head screwdriver
- Drill



FOR USE ONLY WITH LOW VOLTAGE LANDSCAPE POWER UNITS THAT DO NOT EXCEED 25 AMPS, 15 VOLT MAXIMUM.

WARNING: Luminaires must be installed in accordance with the National Electrical Code (NEC) and local codes. Failure to do so will void the warranty and may result in serious injury and/or damage to the luminaire.

SAFETY WARNING: Luminaire can become very hot depending on lamp wattage used. Lens and metal around lamp can become hot enough to blister hands. Particular care should be taken not to locate luminaires where small children can reach them if high wattage lamps are used.

LUMINAIRES ARE NOT TO BE INSTALLED WITHIN 10 FT. (3.05M) OF A POOL OR SPA. SECONDARY CABLE IS NOT TO BE BURIED MORE THAN 6". WHEN USING MULTIPLE LUMINAIRES, LOAD IS NOT TO EXCEED THE TOTAL WATTS OF TRANSFORMER RATING. DO NOT USE EXTENSION CORDS ON POWER UNITS.

NOTE: Always use UL recognized wire connectors for connections.

NOTE: Save these instructions for future reference.

INSTRUCTIONS FOR EXISTING WALLS/WOOD DECK MOUNTING:

1. To prevent electrical shock, disconnect transformer from electrical supply before installation or service.
2. Loosen the two (2) set screws on sides of luminaire cover and remove cover from backplate.
3. Position backplate on final mounting location and mark hole locations for mounting screws.
4. Drill pilot holes for #10 mounting screws (by others).
5. Install backplate on final location and secure tightly with two (2) #10 screws (by others).
6. Install cover and tighten the two (2) set screws on sides of cover.
7. Strip the two (2) leads from the luminaire pigtail wire. Using the two (2) silicone filled safety connectors (provided), connect the leads from the luminaire to the main supply cable leads.

NOTE: Luminaires are supplied with 36" of 18-2 cable pigtail for secure connection to the main supply cable.

8. Provide power to the luminaire and check for proper operation.

**IMPORTANT SAFETY INSTRUCTIONS
THE LIGHTED LAMP IS HOT!!**

WARNING: TO REDUCE THE RISK OF FIRE, OR INJURY TO PERSONS:

1. Turn off/unplug and allow to cool before replacing lamp.
2. Lamps get hot quickly! Contact only switch/plug when turning on.
3. Do not touch hot lens, guard or enclosure.
4. Keep lamp away from material that may burn.
5. Do not touch the lamp at any time. Use a soft cloth. Oil from the skin may damage lamp.
6. Do not operate luminaire fitting with a missing or damaged cover.

LAMP INSTALLATION/REPLACEMENT:

CAUTION: Do not exceed maximum wattage marked on luminaire label.

1. To prevent electrical shock, disconnect transformer from electrical supply before service.
2. Loosen the two (2) set screws in luminaire cover.
3. Remove cover and lens to expose lamp.

NOTE: DO NOT touch Halogen lamp with bare hands. Always use a soft cloth or the plastic wrapping (if available) from the lamp to handle the lamp.

4. Re-install cover and tighten set screws evenly.

NOTE: Halogen lamps must be protected from moisture and dust at all times. Always re-install cover and lens correctly after lamp maintenance.