

## Passive Infrared Wall Switches



LOS-SIR



LOS-SIR-M



LOS-SIR-HD



LOS-S2IR-HD

The LOS-SIR Series of infrared sensors offer a direct and quick replacement of wall switches for stand-alone line voltage switching of small spaces. The advanced microprocessor in combination with infrared technology detects occupancy and reduces energy consumption. They install quickly and easily and provide excellent energy savings as well as reliable motion detection.

### General Features

- Dual 120/277 V<sub>~</sub> operation
- Integral adjustable light level sensor (except LOS-SIR-M)
- Compatible with electronic ballasts and PL lamps
- No minimum load requirement
- High immunity to RFI and EMI
- 180° field of view
- Adjustable time delay

### Model-Specific Features

- M models conform to residential Title 24 (manual on, auto off)
- HD models have heavy-duty lens to prevent damage
- S2IR-HD model has dual-level switching, allowing for two primary input circuits, each with independent switching

### Models Available

Cat. No.	Color	Coverage (sq.ft.)	Special Features
LOS-SIR-WH	White	900	Auto On/Auto Off
LOS-SIR-IV	Ivory	900	Auto On/Auto Off
LOS-SIR-M-WH	White	900	Manual On/Auto Off
LOS-SIR-M-IV	Ivory	900	Manual On/Auto Off
LOS-SIR-HD-WH	White	1,000	Heavy-duty lens
LOS-S2IR-HD-WH	White	1,000	Dual-circuit; Heavy-duty lens

### General Operation

The LOS-SIR Series of sensors monitor an established area through a PIR lens and are alerted by a moving heat source, such as a human body, which causes the sensor to automatically switch "ON" available lighting. With a fully adjustable time delay, sensitivity, and light level control, convenience and performance are optimized. The sensor's internal circuitry allows it to operate with any lighting load, including electronic ballasts, PL lamps, and exhaust fans.

<b>Job Name:</b>	<b>Model Numbers:</b>
<b>Job Number:</b>	

## Specifications

### Adjustability

- 30 seconds to 30 minutes time delay
- 20% to 100% sensitivity
- Auto/Off push switch for override to "OFF"

### Maximum Load Requirements

- 120 V: 1000 W ballast, 800 W incandescent
- 277 V: 1800 W ballast

### Sensing

- Integral light level sensor (except LOS-SIR-M)  
LOS-SIR and HD models 5 to 200 foot-candles
- Optical lens rejects "white light" and prevents false triggering
- Multi-segment IR lens (HD models have tamper-resistant heavy-duty lens)

### Power

- Operating voltage: 120/277 V~, 50/60 Hz
- Compatible with all electronic ballasts and PL lamps
- No minimum load requirement
- S2IR-HD controls 2 circuits independently
- UL and CUL listed

### Operating Environment

- Temperature: 0°F to 100°F (-18°C to 38°C)
- Relative humidity: less than 95%, non-condensing
- For indoor use only

## Range Diagrams

LOS-SIR, LOS-SIR-M models

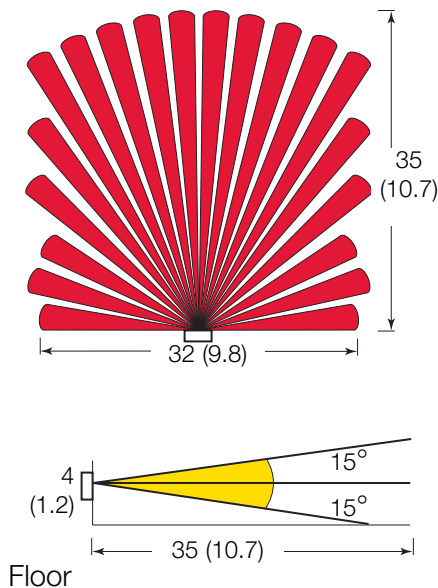

LOS-SIR-HD models

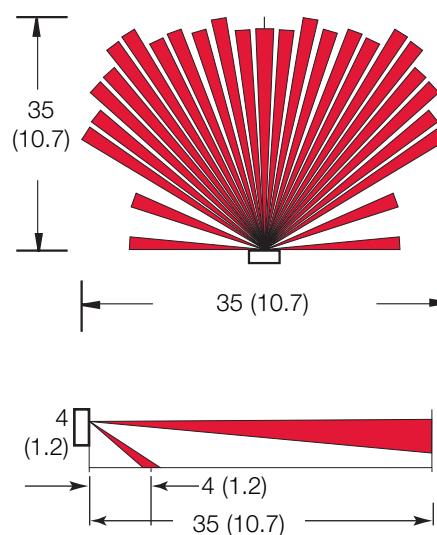

Measurements are in feet (m)

<b>Job Name:</b>	<b>Model Numbers:</b>
<b>Job Number:</b>	

### Dimensions

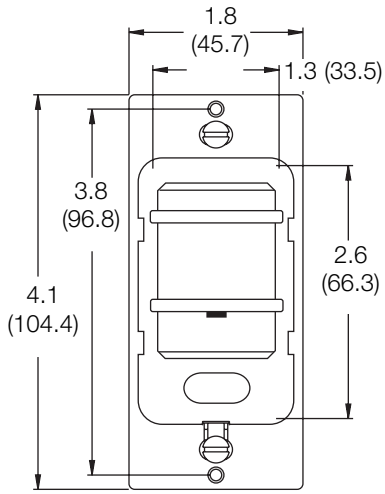

LOS-SIR, LOS-SIR-M Front View

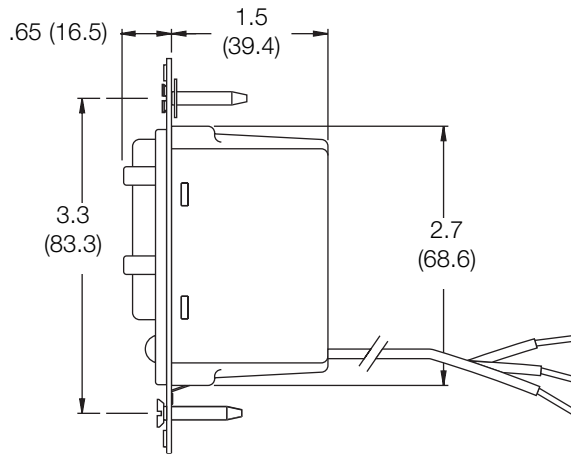

LOS-SIR, LOS-SIR-M Side View

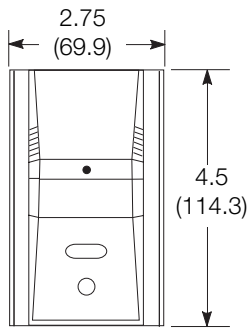

LOS-SIR-HD Front View

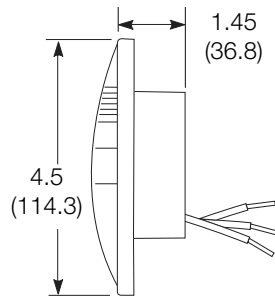

LOS-SIR-HD Side View

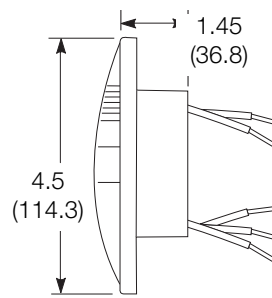

LOS-S2IR-HD Side View

Measurements are in inches (mm)

Mount using a single gang electrical box.  
Use in either single pole or 3-way application.

<b>Job Name:</b>	<b>Model Numbers:</b>
<b>Job Number:</b>	

# Wiring

## 1-Way Wall Switch Sensor

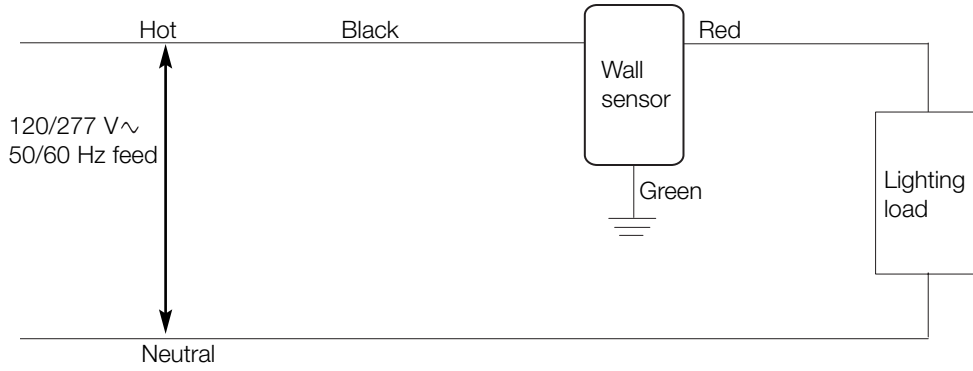

## 3-Way Wall Switch Sensor

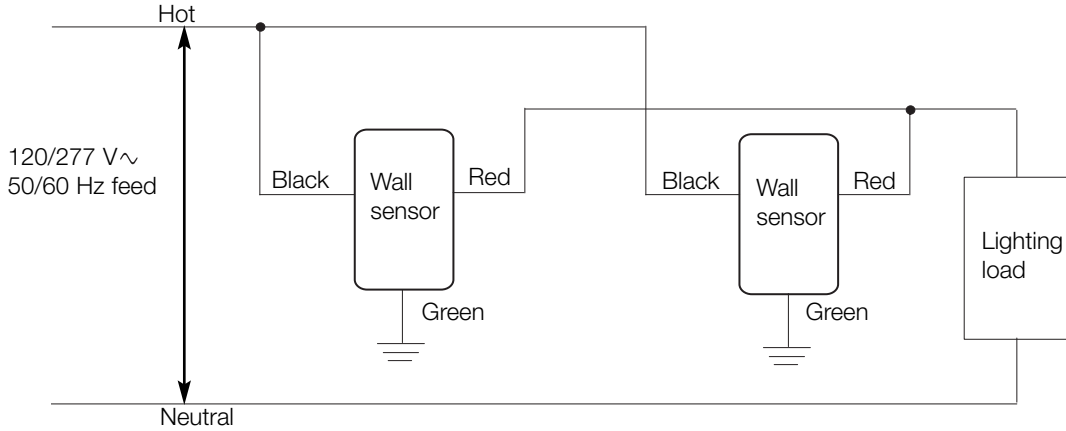

## 1-Way Dual-Circuit Wall Switch Sensor

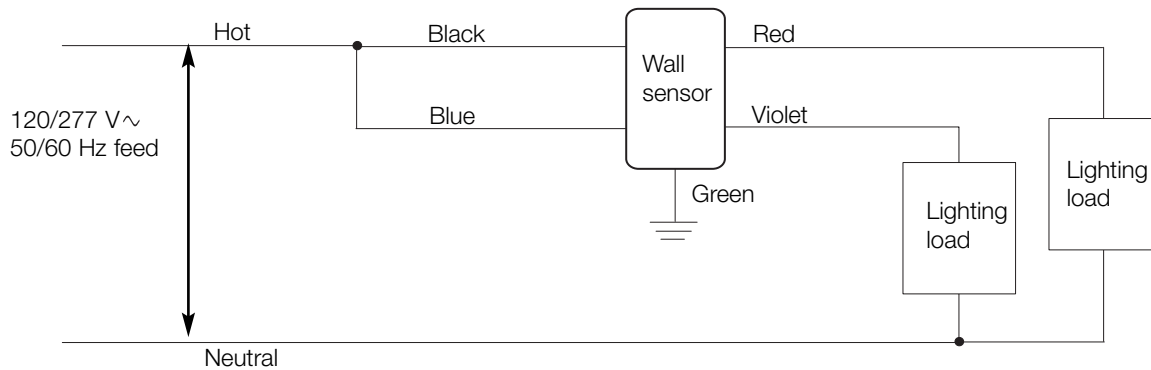

<b>Job Name:</b>	<b>Model Numbers:</b>
<b>Job Number:</b>	

### 3-Way Dual Circuit Wall Switch Sensor

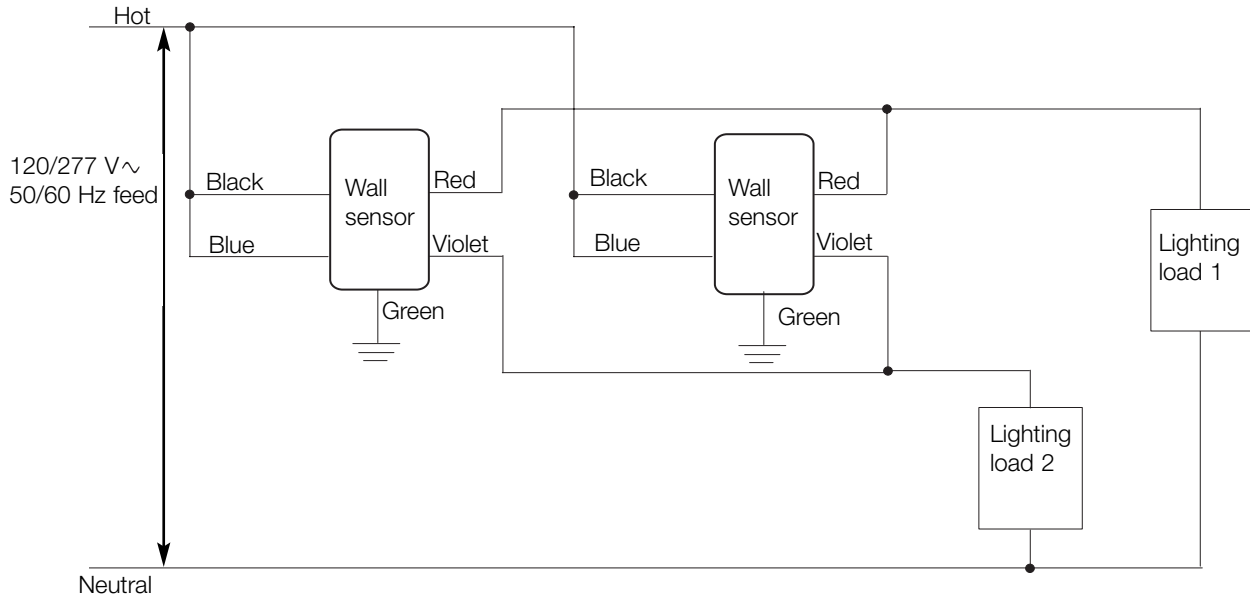

### Dual-Circuit Sensor Used to Switch a Single Load

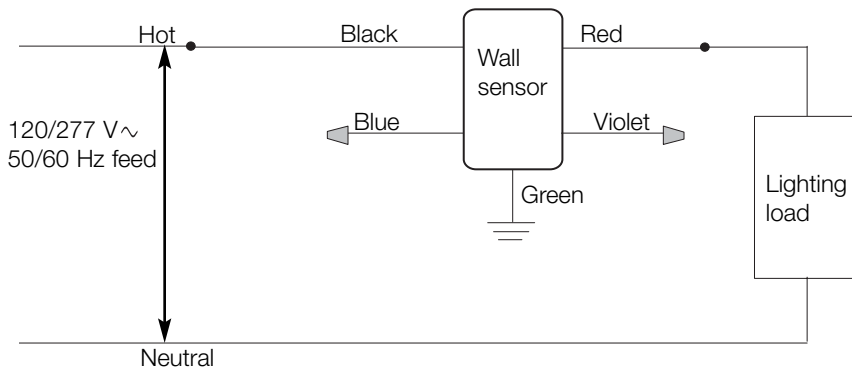

Job Name:	Model Numbers:
Job Number:	

## Installation

Mounts as a direct replacement for a standard wall switch.

1. Warning: Turn power OFF at circuit breaker or remove fuse.
2. Remove switch mounting screw. (Turn screws counterclockwise.) Pull switch from wall.
3. Disconnect switch wires.

Screw Terminals: Turn screws counterclockwise to loosen.

Backwired: Insert screwdriver and pull wire out.

4. Wire the switch by referring to the appropriate Wiring Diagram.
5. Mount and align switch. Replace wallplate.
6. Turn power ON.

Note: Lights may not come on when first powered up.

Allow 60 seconds warm-up for device to reach normal operation.

## Adjustments

1. Remove the cover located between the sensor lens and the push button by inserting a small flathead screwdriver into the notch located on the top of the cover. Gently lift the screwdriver upward to unlatch cover. For HD models, the cover is at the top of the switch; slide it upward to remove.
2. Time Delay: Turn the adjustment on the left labeled "T" fully counterclockwise to the minimum setting (30 seconds). This must be set at the minimum while testing the sensor and adjusting the photo cell and sensitivity settings. Turning the adjustment fully clockwise puts the unit into bypass, which keeps the light on regardless of occupancy conditions.
3. Sensitivity: The sensitivity adjustment is in the center and marked "S". Adjust the sensitivity to avoid unwanted detection, such as hallway traffic or adjacent movement. Turn the setting counterclockwise to decrease sensitivity, clockwise to increase sensitivity.
4. Photo Cell: The photo cell is used to detect if other light sources, such as sunlight, are enough to illuminate the space without turning on the lights. If use of the photo cell is desired, see the Photo Cell Adjustments below. If use of the photo cell is not desired, turn the photo cell adjustment (located on the right, labeled "A") fully clockwise to the maximum setting. This will allow the sensor to turn the light on and off regardless of ambient light conditions
5. Vacate the room until the lights turn off.

### Photo Cell Adjustment (except LOS-SIR-M)

1. Adjust the room lights to the same level for which you want the sensor to turn on (use the blinds, shades, etc.).
2. Set the time delay to the minimum setting by turning the adjustment fully counterclockwise.
3. Turn the ambient control setting fully counterclockwise. Leave the room and allow the lights to turn off.
4. Re-enter the room and slowly turn the ambient control clockwise until the lights switch on.  
NOTE: Avoid blocking the lens and sensor while making this adjustment.
5. Ambient threshold is now set at the ambient light level present at the sensor.

<b>Job Name:</b>	<b>Model Numbers:</b>
<b>Job Number:</b>	