

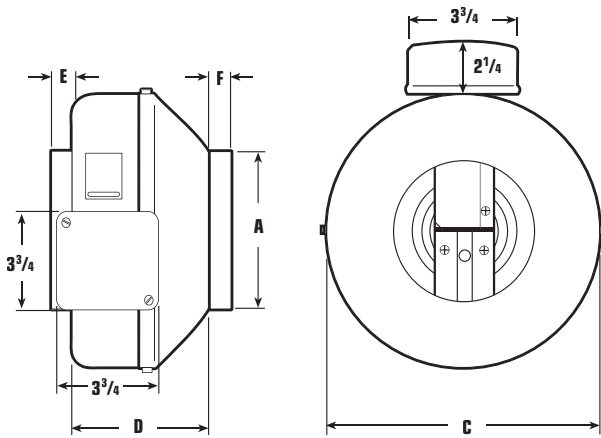

SUBMITTAL DATA

FG SERIES

Inline Centrifugal Fans



STANDARD FEATURES

- Airtight galvanized steel housing
- Powered by external rotor motorized impeller
- Permanently lubricated sealed ball bearings
- 100% speed controllable
- Automatic reset thermal overload protection
- Prewired electrical box
- Five-year factory warranty

Model	A	C	D	E	F	Metal Gauge	Avg Wt. (lbs.)	Energy Star
FG 4	3 7/8	8 3/4	6 1/2	1	1	22	7	✓
FG 4XL	3 7/8	9 3/4	6 15/16	1	1	22	8	
FG 5	4 7/8	8 3/4	5 1/2	1	1	22	7	✓
FG 5XL	4 7/8	9 3/4	5 15/16	1	1	22	8	
FG 6	5 7/8	11 3/8	6	1	1	22	10	✓
FG 6X	5 7/8	11 3/8	6	1	1	22	10	✓
FG 6XL	5 7/8	13 1/8	6 5/8	1	1	22	12	✓
FG 8	7 7/8	13 3/8	6	1 1/8	1 1/8	22	12	✓
FG 8XL	7 7/8	13 3/8	6	1 1/8	1 1/8	22	13	✓
FG 10	9 7/8	13 3/8	4 11/16	1 1/8	1	22	12	✓
FG 10XL	9 7/8	13 3/8	5 7/8	1 1/8	1	22	14	✓
FG 12	11 7/8	16	8 1/4	1 1/16	1 3/16	22	18	✓
FG 12XL	11 7/8	16	8 1/4	1 1/16	1 3/16	22	21	✓



Look for Energy Star models in dimensional data chart.

All dimensions in inches.

Fan Specifications							Motor Specifications				
Line	Qty	Model No.	Tag	CFM	SP	Fan RPM	Watts	Volts	Phase	Hertz	Encl
1											
2											
3											
4											
5											

Accessory Items	1	2	3	4	5	Accessory Items	1	2	3	4	5
<input type="checkbox"/>						<input type="checkbox"/>					
<input type="checkbox"/>						<input type="checkbox"/>					
<input type="checkbox"/>						<input type="checkbox"/>					
<input type="checkbox"/>						<input type="checkbox"/>					
<input type="checkbox"/>						<input type="checkbox"/>					

Project: _____ Submitted: _____
 Customer: _____ Approved: _____
 Location: _____



United States 1712 Northgate Blvd. • Sarasota, FL. 34234 • 1.800.747.1762 • www.fantech.net
 Canada 50 Kanalfakt Way • Bouctouche, NB E4S 3M5 • 1.800.565.3548 • www.fantech.ca

Article #: 450369
 Rev Date: 052107

Fantech, reserves the right to modify, at any time and without notice, any or all of its products' features, designs, components and specifications to maintain their technological leadership position.